

110 Parkway Drive, Truro Heights
Nova Scotia, Canada, B6L 1N8
support@oceansonics.com
www.OceanSonics.com

JPX Battery Pack User Guide

Version 1.0



OCEAN SONICS
Giving Our Oceans A Voice

Table of Contents

Introduction.....	3
Safety.....	3
Included tools and spare parts	3
General Specs Overview.....	4
Battery Pack User Guide.....	5
Removing the Endcap.....	6
Installing new Batteries.....	9
Replacing the Endcap.....	11
Opening and Closing the Vent Plug.....	14
Opening the Pressure Relief Valve.....	15
Confirming Voltages.....	15
Deployment	
Deploying the Battery Pack.....	16
Recovery of the Battery Pack.....	17
Maintenance	
Cleaning the Battery Pack.....	17
Anodes.....	18
Cleaning the Seal.....	18
APPENDIX A: O-Ring Replacement Instructions.....	19
APPENDIX B: icListen Setup.....	20
Marco.....	20
Lucy.....	20
APPENDIX C: Technical Drawings.....	21

Introduction

Welcome to the JPX Battery Pack User Guide—a comprehensive resource designed to empower you with the knowledge and confidence to make the most of your portable power solution.

The Ocean Sonics JPX Battery Pack is a submersible unit that provides additional power to one or more hydrophones for long-term deployments. The pack uses a maximum of 72 D-cell batteries that are field-changeable and can provide power for one hydrophone for 30-90 days*. All battery packs are made of lightweight glass fiber composite case. There are 3 types of end cap materials for varying depth ratings for 200m (Engineered Plastic), 900m (Anodized Aluminum) and 3500m (Titanium).

In this guide, you will be provided with a breakdown of the essential features, functionalities, and safety measures that our battery pack offers. Whether you're a seasoned hydrophone and battery pack user, or new to Ocean Sonics equipment this guide is tailored to meet your needs. We understand that in a world increasingly dependent on technology, a dependable and well-understood power source is paramount. With clear instructions, insightful tips, and a focus on safety, this Battery Pack User Guide aims to enhance your experience, extend the life of your hydrophones, and ensure your interactions with our product are as efficient and enjoyable as possible. So, let's delve into the world of portable power and unlock the full potential of your battery pack.

*Varies depending on differing brands of batteries / Value based on typical cells

Safety

1. Always open pressurized vessels with additional care
2. After use in water, ensure battery pack unit is dry before opening
3. After use in water, ensure users hands are dry when securing contact plate
4. Always use PPE safety gear when working with electrical equipment
5. Please follow all safety and danger guidelines of personally purchased batteries

Included tools and spare parts

JP2-BX

1. Included Tools/Spares
2. 1 x 4mm Hex Key
3. 2 x 02-255 O-Rings
4. 10mL Molykote 44 Grease
5. 2 x M8x50 Soft Point Set Screws

JP9-BX

1. Included Tools/Spares
2. 1 x 4mm Hex Key
3. 1 x 3mm Hex Key
4. 2 x Can Anode
5. 1 x Endcap Anode
6. 2 x 02-255 O-Rings
7. 10mL Molykote 44 Grease
8. 2 x M8x50 Soft Point Set Screws

General Specs Overview

Battery Pack Physical Specifications		
	JP2	JP9
Material	Acetal	Anodized Aluminum
Overall Length	70cm	
Diameter	18cm	
Weight in air (kg)	Alkaline Cells: 18.5 Lithium Cells: 15.7	Alkaline Cells: 26.0 Lithium Cells: 23.2
Weight in seawater (kg)	Alkaline Cells: 8.52 Lithium Cells: 5.72	Alkaline Cells: 16.0 Lithium Cells: 13.2
Weight empty (in air)	Alkaline Cells: 16 Lithium Cells: 16	Alkaline Cells: 16 Lithium Cells: 16
Anode Replacement Interval	NA	Endcap: 8000h Body: 4000h

Battery Pack Battery Specification		
Number of Channels	Alkaline	Lithium
Normal Voltage (range)	28 V (15 to 29)	22 V (18 to 25)
Battery Capacity	1500 Wh	4500 Wh

Number of days of battery life		
Number of Channels	Alkaline	Lithium
1	30	90
2	15	42
3	10	26
4	7.5	19

Removing the Endcap

The endcap must be removed to fill the battery pack with the D-Cell batteries or to replace the depleted batteries. When replacing the batteries, ensure the outside of the battery pack is completely dry before removing the endcap to reduce the risk of water droplets falling inside the battery pack.

a) If the battery pack has a manual vent plug (shown below), loosen the vent with a flat head screwdriver by at least three full turns. This will vent the gas generated by Lithium-Ion batteries in use. If the battery pack has a Pressure Release Valve (PRV), any required venting is done automatically and this step is not required.



Figure 01: Manual vent plug circled on a JP2-B3 and JP9-B3

b) Fully remove the four radial M6 flat head screws with a 4mm hex key. Ensure these screws are kept safe as they will be required to reinstall the endcap.

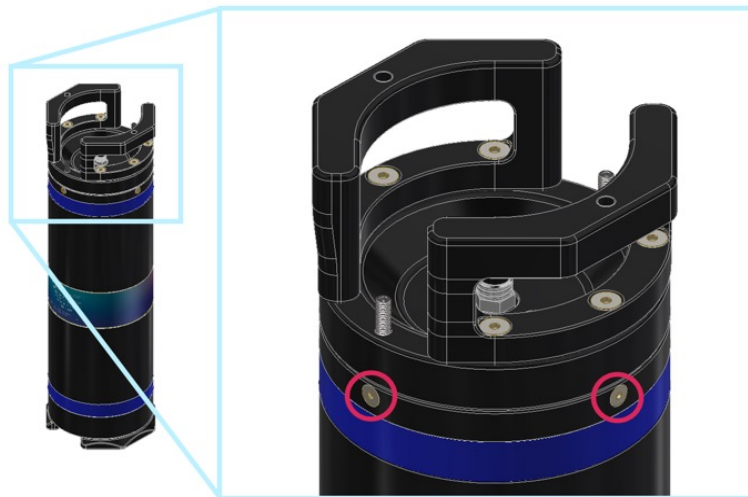

Figure 02: Radial screws circled on a battery pack to their show location

c) Using a 4mm hex key, tighten the jacking screws in the endcap to overcome the friction in the O-Ring seal.

NOTE: Alternate tightening each jacking screw every turn. Tightening one jacking screw too much more than the other will apply uneven loads to the sealing surface and may damage the seal.

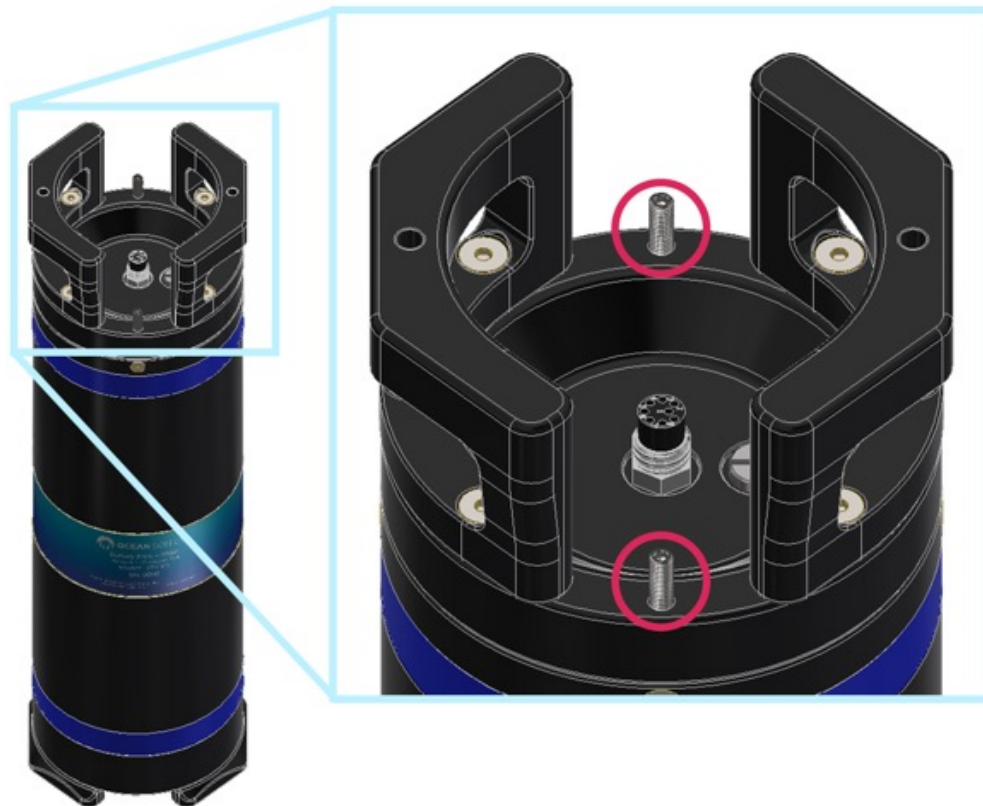

Figure 03: Jacking screws circled

WARNING: Soft point screws must be used to lift the endcap. Failure to do so can generate wear particles that compromise the sealing interface.

d) Once one O-ring is visible, the endcap may be grasped by the handles and pulled straight out of the can. The feet protrude slightly from under the can, and they may be used as footholds to help separate the endcap from the can. If the endcap cannot be removed easily, tighten the jacking screws in order to separate the endcap from the can until the second O-Ring is visible. Once the endcap is removed, flip it upside-down so the contact plate is facing up.

NOTE: Once the endcap is removed, the sealing surfaces are vulnerable to scratches and dents. Be extremely careful when handling the separate parts. Damage to the sealing surfaces or O-Rings can compromise the seal and lead to water ingress during use.



Figure 04: Battery pack showing feet placement for end cap removal



Figure 05: Battery pack sealing surfaces are shown in red

Installing New Batteries

- a) Loosen the 3 thumb screws on contact plate A until it can be separated from the assembly.
- b) Carefully remove contact plate A from the assembly exposing the 12 battery columns.

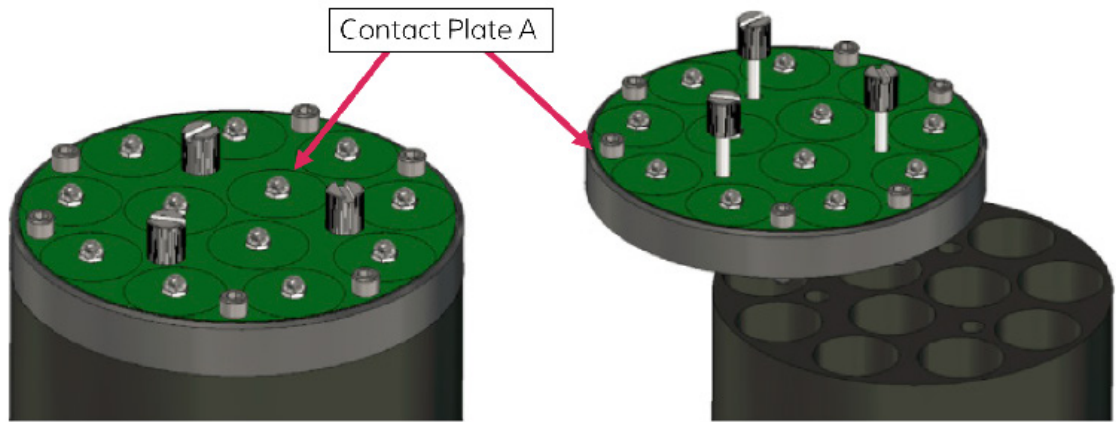
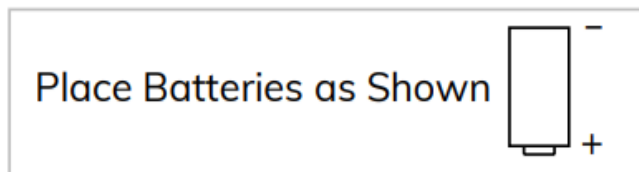

Figure 06: Contact Plate A, showing closed (left) and opened (right)

- c) Install batteries in the correct orientation as indicated by the sticker on the side of contact plate A. All batteries are installed in the same orientation with 6 D-Cell batteries in each column.



Important: Ensure the batteries are the correct type for your battery pack (alkaline/lithium) and that the switch is in the correct position prior to installation.

Do not mix battery types (i.e., different manufacturers or different battery chemistries)

Important: Ensure all batteries are installed in the same orientation. Failure to do so can result in irreversible damage to the contact plate and battery pack.

d) Installing batteries can be done by taking out all the foam inserts and filling each individually. Or pushing the batteries down from the top, without taking out foam.



Figure 07: Direction of batteries in foam inserts

e) Once batteries have been inserted, replace the contact plate A.

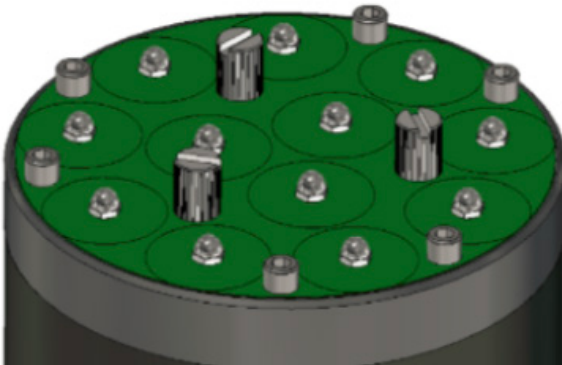

Figure 08: Contact Plate A replaced on top of foam inserts

f) Hand-tighten the thumb screws into place. This should be done with clean dry hands to avoid potential minor shocks. Ensure the screws are secure as they complete an electrical circuit.

Replacing the Endcap

Before replacing the endcap, ensure that both sealing surfaces are immaculately clean. A single grain of sand is enough to scratch the sealing surface and compromise the O-ring seal! (See Cleaning the Seal under Maintenance)

a) Back out all jacking screws from the endcap so they are no longer protruding below the endcap as seen in Figure 9.

TIP: Use fingers to hand-loosen the jacking screws if using the hex key is challenging.



Figure 09: Sealing surface of the battery pack shown in red.

NOTE: We recommend replacing the O-rings after every deployment, however if the O-rings are to be reused, ensure both O-rings are completely wetted with the supplied O-Ring lubricant. See the O-ring replacement section for instructions on how to properly replace the O-Rings.

b) Carefully slide the endcap assembly into the can until the O-rings are just exposed.

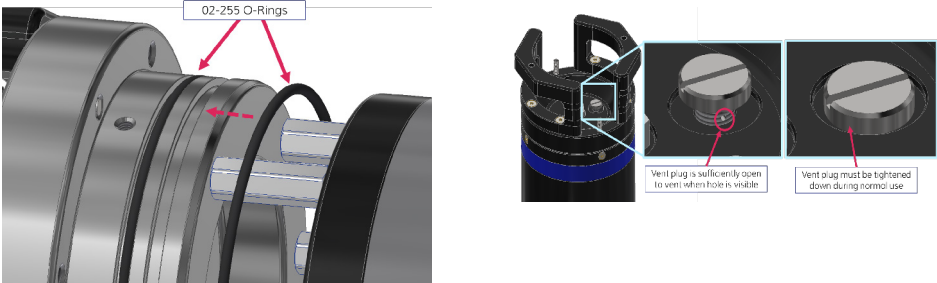

Figure 10: Endcap replacement onto battery can.

c) If the battery pack has a manual venting plug, open the vent plug with at least three counterclockwise turns.

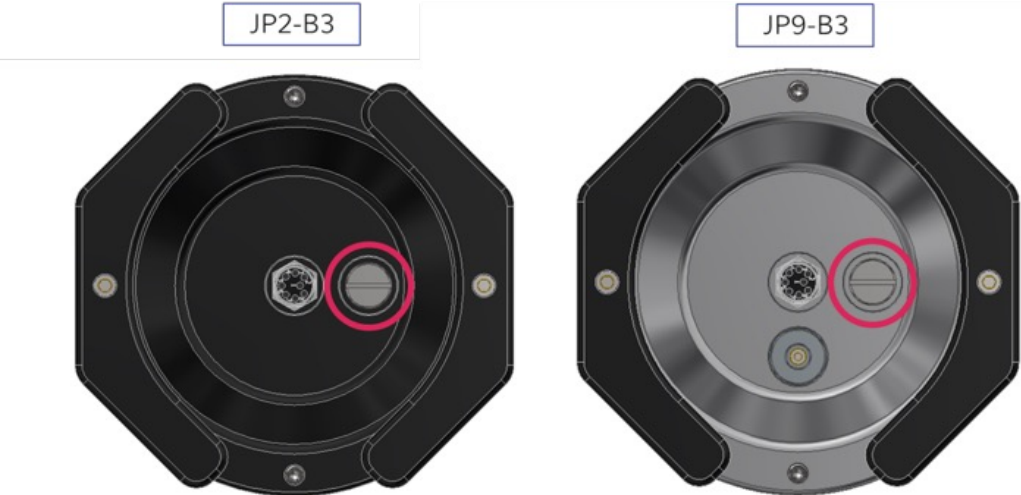

Figure 11: Manual venting plug circled on the JP2-B3 and JP9-B3.

d) Align the four radial retaining holes as best you can. It does not matter which specific hole on the endcap aligns with a specific hole on the can.



Figure 12: Radial holes from the end cap and body circled to show the alignment.

e) **Push the endcap all the way in.** Some bodyweight may be required to push the endcap home, however provided the O-rings are properly lubricated, it should not require excessive force. If it seems to be requiring excessive force, remove the endcap and verify the jacking screws are removed and nothing in the can is interfering.

f) Observe one of the four radial holes and ensure the clearance hole is aligned with the threaded hole. Do not use the fastener to align the two holes. The endcap should be able to be twisted to align the two holes fairly closely.

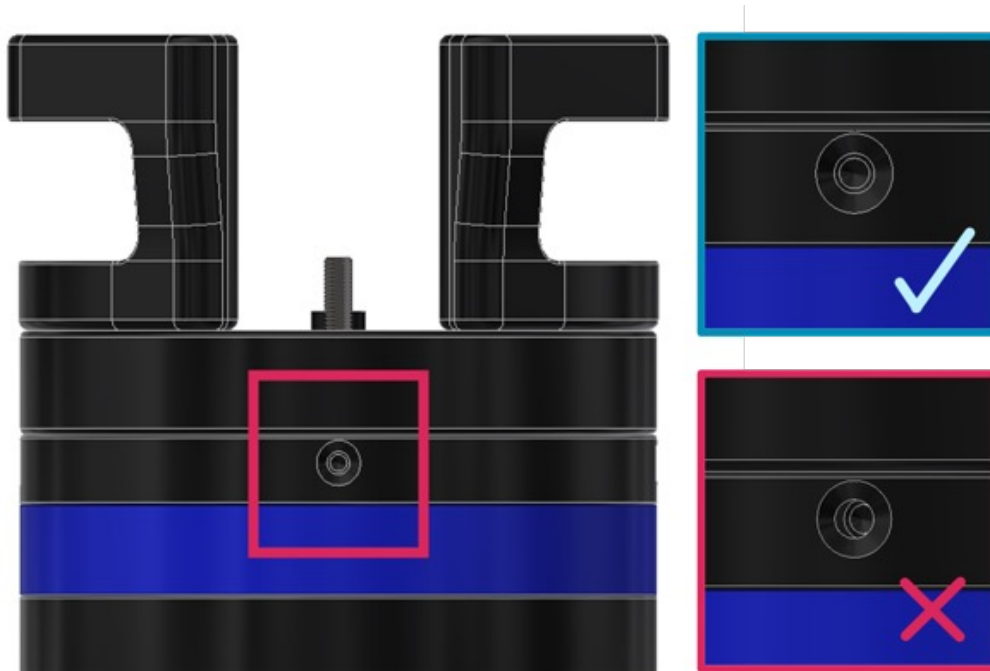

Figure 13: Radial screw holes that are properly aligned

TIP: Do not over tighten the radial M6 flat head screws as it will damage the threads.

g) Using a 4mm hex key, screw the four radial M6 flat head screws into the radial retaining holes until snug. The integrity of the seal is not affected by how tight the screws are, so there is no need to tighten them excessively.

h) If the battery pack is a JP2-B1 or JP9-B1, tighten the vent plug firmly. Confirm if your model has a vent plug or pressure relief valve and follow the appropriate steps below

i) Remove jacking screws before deployments and replace with M8 x 20 nylon set screw.

Opening and Closing the Vent Plug

Always close the vent plug for deployment.

Ensure the vent plug is in the closed position and fully seated against the face of the endcap (as seen below).

NOTE: The Vent Plug can be adjusted with the use of a flat head screwdriver or a coin.

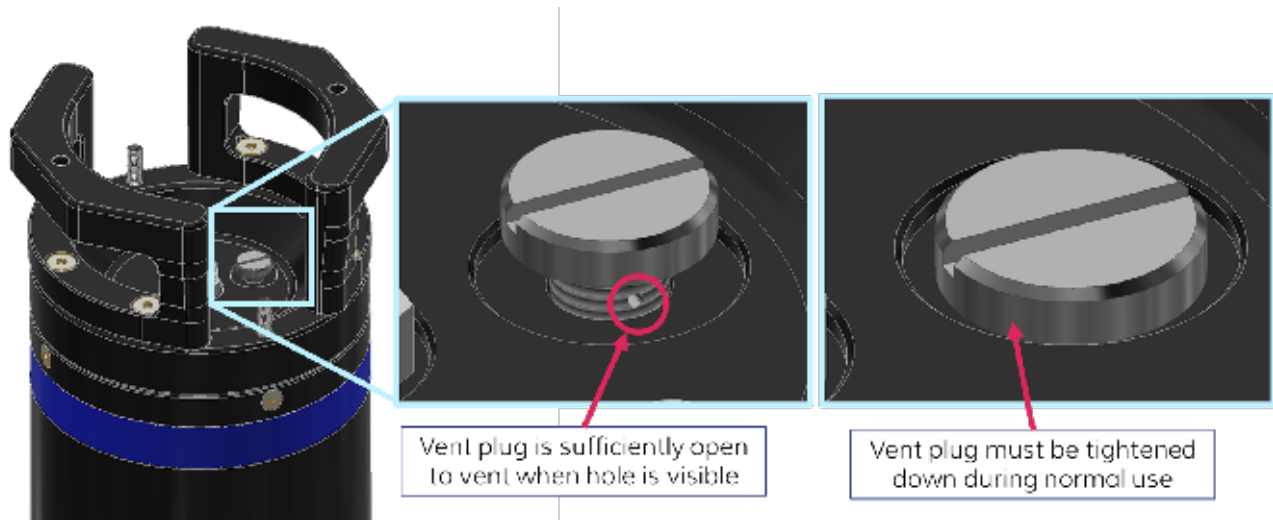

Figure 14: Vent plug direction showing open and closed positioning

Pressure Relief Valve Directions

Do NOT adjust the Pressure Relief Valve. Manual venting is not required. A pressure relief valve will automatically vent to protect against accidental overpressure from battery outgassing.

NOTE: If you are redeploying the battery pack, check the anode (see Anodes section below)

Confirming Voltages

A voltmeter should be used to confirm the proper voltage is being supplied to the exterior bulkhead connector.

- a) Place the negative voltmeter lead (black) into pin 1 of the MCBH8F bulkhead connector on the battery pack end cap for the common connection (pinout below).
- b) Place the positive voltmeter lead (red) into pin 7 (pinout below).

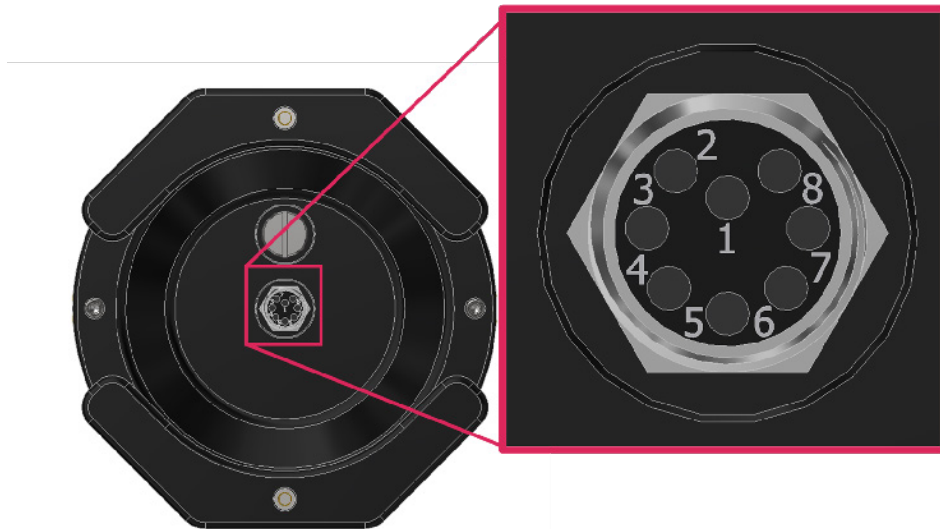

Figure 15: MCBH8F Bulkhead Connector Pinout

Fresh Alkaline batteries should measure approximately 27-29 VDC.

Fresh Lithium batteries should measure approximately 21-25 VDC.

Deploying the Battery Pack

The battery pack is now ready to provide power to your hydrophone(s) for your deployment.

- a) Use the icListen Quick Start to setup icListen for deployment, set the time on the hydrophone, sampling rates and duty cycling if needed (See Appendix B)
- b) Once the hydrophone is recording or set to record in the future, unplug the hydrophone from the test cable and connect to the battery pack.
- c) The hydrophone can be plugged directly into the top connector on the battery pack (most common with in-line battery pack frame) or into a cable connected to the top of the battery pack.
- d) If using the in-line battery pack frame place the battery pack and icListen in the frame for a mooring deployment.

Setup:

- A. icListen
- B. Battery Pack
- C. Battery Pack Cage
- D. Rope
- E. Anchor
- F. Floats

Note: An acoustic release can be used to retrieve a mid-water mooring deployment.

- e) Deploy your hydrophone and collect data for up to 3 months.

Figure 16: Battery Pack deployment illustration in an in-line battery pack frame

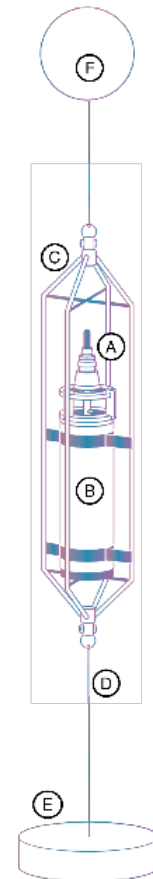

Recovery of the Battery Pack

- a) After recovery, inspect for damage and vent the Battery Pack to equalize pressure if the model has a vent plug.
 - i) If the model has a vent plug: manual venting can be done with the use of the vent plug located on the face of the end cap. The vent plug can be adjusted with the use of a flat head screwdriver or a coin.
 - ii) Slowly turn screw 1/4 turn allow to vent and repeat until open.
 - iii) If the model has a pressure relief valve: Do not adjust the pressure relief valve. Manual venting is not required. A pressure relief valve will automatically vent to protect against accidental overpressure from battery outgassing.
- b) Rinse battery pack with fresh water to clean and ensure dry before opening.
- c) Before opening follow ALL Maintenance procedures.

Cleaning the Battery Pack

- The outside of the battery pack should be thoroughly rinsed with fresh water after each deployment to remove saltwater and debris.
- The battery pack should only be opened when it is safe to do so in a clean and dry environment without the chance of water entering the inside of the tube.
- Dry the endcap before opening so water does not drip into the tube.
- Use the Removing End Cap for instructions on opening the battery pack.
- O-rings and O-rings surfaces should be cleaned after deployment and replaced if any abnormalities are seen or felt (see Appendix A).
- Once the pack is opened, visually inspect batteries and tube for leaking or corrosion.
- The inside of the tube should always be kept clean and dry.

Anodes

The 900-meter battery pack has an anode to minimize corrosion. The battery pack anodes should be checked and replaced as required after every deployment. It is important that anodes are monitored closely and are not fully consumed. If the anodes are not maintained the battery may become damaged and cause catastrophic failure resulting in a void warranty.

Ocean Sonics suggests replacing the anodes before 25% remaining. If the battery pack is being deployed on a long deployment, it is recommended that you have fresh anodes.

The consumption rate of the anodes depends on many factors (salinity, temperature, water currents, electrical leakage, etc.). After each deployment the anodes should be checked, and the user can gauge this from previous deployments and adjust the replacement schedule as required.

Please contact Ocean Sonics if you require more information on anode replacement or replacement parts.

Cleaning the Seal

- Clean all O-rings and O-ring surfaces with 'KimWipes' or similar lint free tissues.
- Inspect the O-rings to ensure they are seated properly and not damaged.
- Inspect the O-rings surfaces to ensure they are not damaged.
- Lubricate all O-rings and O-ring surfaces.

APPENDIX A: O-Ring Replacement Instructions

1. Carefully remove used O-rings using a plastic O-ring pick.
2. Thoroughly clean grooves in end cap using lint-free wipes and isopropyl alcohol.
3. Inspect grooves for damage, scratches and debris.
4. Carefully clean and inspect new O-rings and backup rings prior to installation.
5. Apply Molykote 44 O-rings lubricant or equivalent to O-rings as per manufacturer's procedure.
6. Install O-rings and backup rings as shown in Figure. 12
7. Clean and inspect O-ring sealing surface in pressure case.
8. Apply Molykote 44 to sealing surface prior installing end cap.

CAUTION: Using metal tools to remove or position O-Rings may cause damage to the sealing surface. Use plastic tools only.

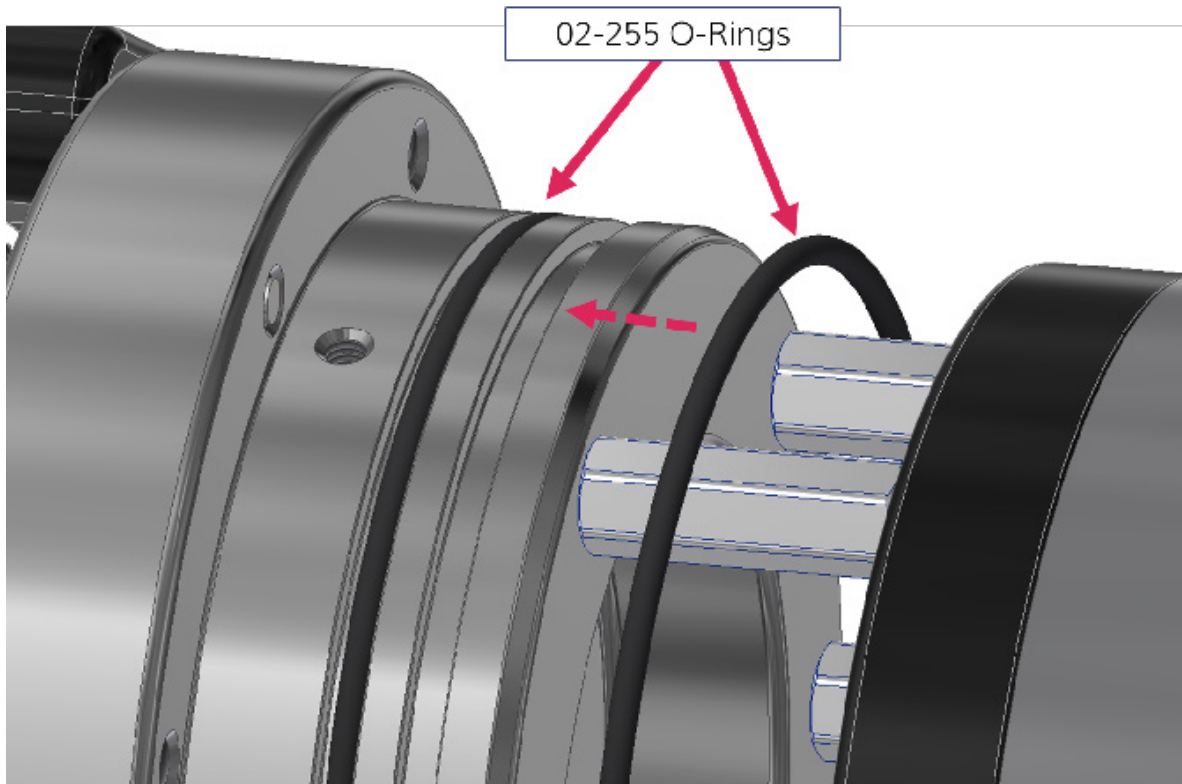

APPENDIX B: icListen Setup

Marco

1. Open Marco
2. Double click on hydrophone serial number to open webpage.
3. Go to Data -> Retrieve Page
4. Ensure all previously recorded data is deleted from the hydrophone so the maximum amount of data can be recorded during the deployment.
5. Under Operations -> Set Time from computer (if hydrophone is not showing correct date/time set using the computer.)
6. Under Settings Tab -> Data Collection.
7. Choose appropriate settings.
 - a) WAV Sampling
 - b) Spectrum FFT Sampling
 - c) Duty Cycling / Enable Delay if applicable
8. Click Apply and wait for the page to load completely.
9. Verify settings and that all changes performed on webserver have remained.
10. Disconnect unit and connect to Battery Pack.

Lucy

1. Connect to icListen on Lucy.
2. Ensure all previous data has been deleted from hydrophone so maximum amount of data will be recorded.
3. Click on iclisten icon (clipboard) at the bottom right of Lucy display (Setup).
4. Under Link Setup click on Instrument Time (UTC) Set Using PC.
5. Under icListen HF Setup tab.
 - a) Setup sampling for WAV and FFT data.
 - b) Click Apply.
6. Disconnect hydrophone from test cable and connect to Battery Pack.

